

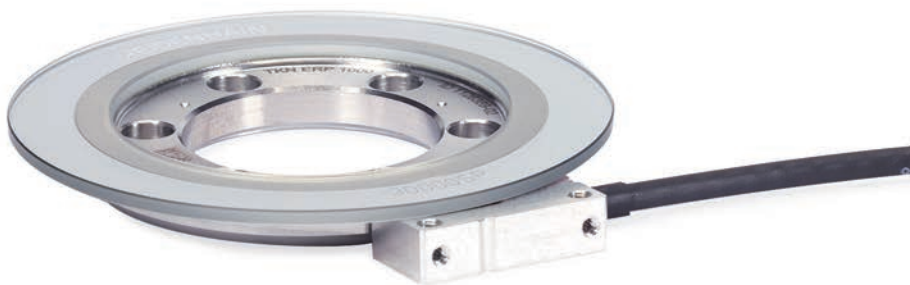

HEIDENHAIN



Product Information

ERP 1000 Series

Angle Encoders
without Integral Bearing

ERP 1000 series

- Very high resolution and accuracy
- Low mass and low mass moment of inertia
- Consisting of an AK scanning head and TKN circular scale

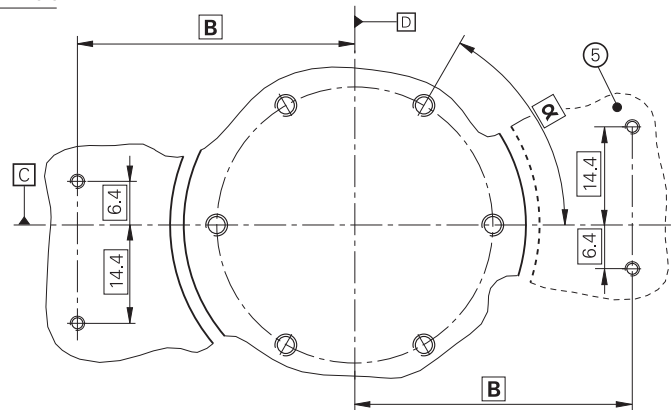
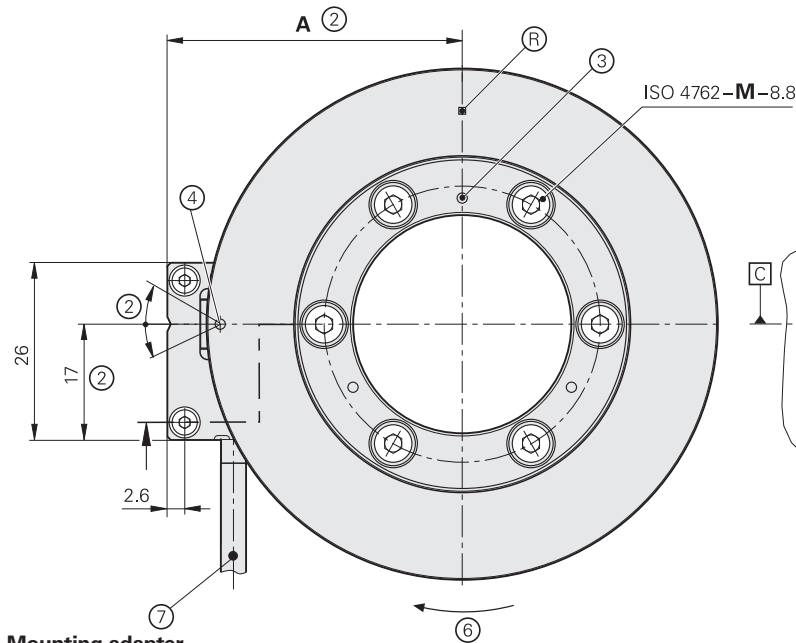
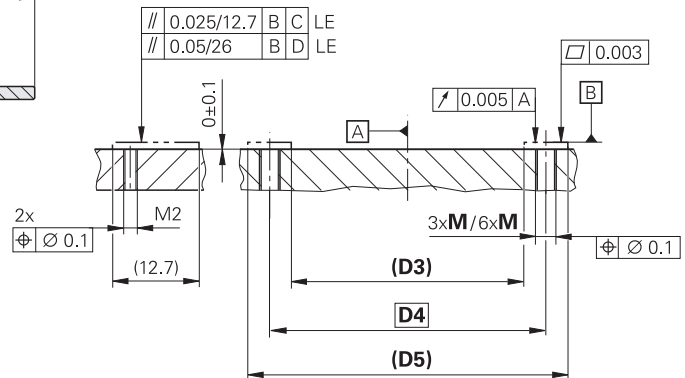
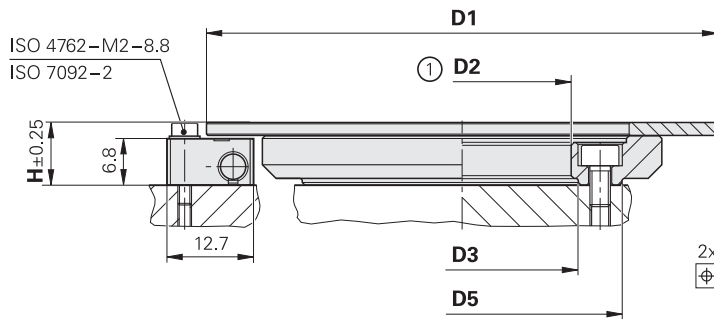

Mounting adapter

mm

 Tolerancing ISO 8015
 ISO 2768 - m H
 < 6 mm: ±0.2 mm

- ▣ = Bearing
- Ⓜ = Reference mark
- 1 = Centering collar
- 2 = Fine adjustment of the scanning head for attainment of optimal incremental signals
- 3 = Marks for circular scale centering (3x120°)
- 4 = Optical centering point
- 5 = For centering of circular scale with two scanning heads
- 6 = Positive direction of rotation
- 7 = Alternative cable outlet and connector are available

LE = Line element (ISO 1101: 2008)
 SP = Signal periods

SP/360°	23000	30000	50000	63000
A	34.08	43.3	60.05	81.05
B	31.48	40.7	57.45	78.45
D1	∅ 57	∅ 75	∅ 109	∅ 151
D2	∅ 13H6	∅ 32H6	∅ 62H6	∅ 104H6
D3	∅ 15.1	∅ 34.1	∅ 64.5	∅ 106.5
D4	∅ 21.5	∅ 40.5	∅ 72	∅ 114
D5	∅ 27.9	∅ 46.9	∅ 79.5	∅ 121.5
H	9.2	9.2	10.2	10.2
α	3 x 120° = 360°	6 x 60° = 360°	6 x 60° = 360°	6 x 60° = 360°
M	M3	M3	M4	M4

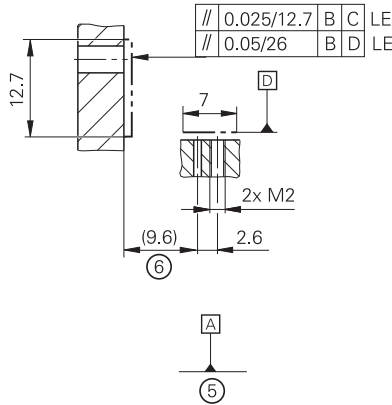
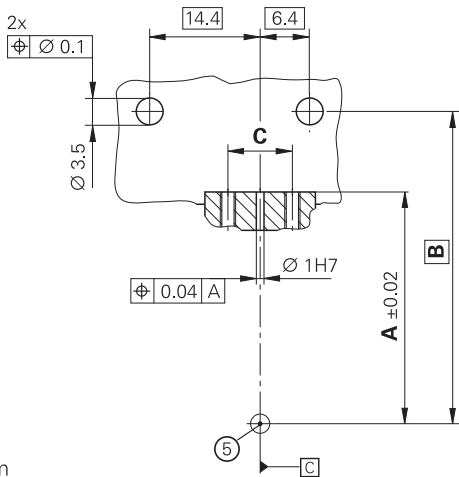
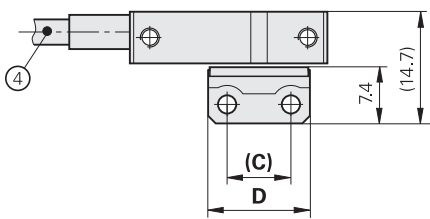
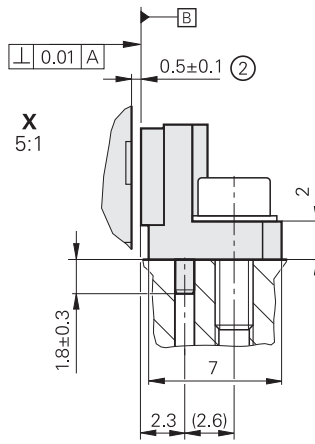
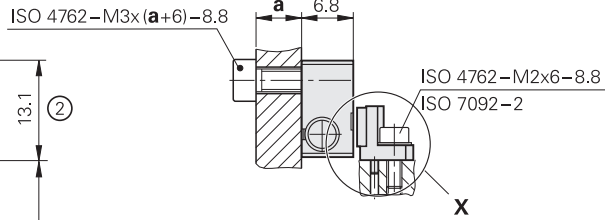
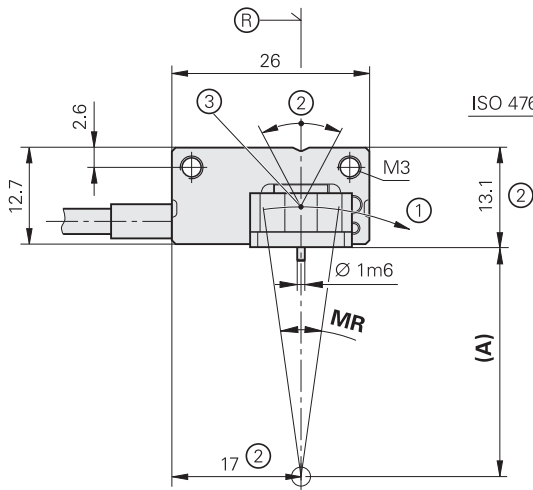

mm

Tolerancing ISO 8015
ISO 2768 - m H
< 6 mm: ±0.2 mm

- ▣ = Bearing
- Ⓜ = Position of the reference mark
- 1 = Positive direction of rotation
- 2 = Fine adjustment of the scanning head for attainment of optimal incremental signals
- 3 = Optical centering point
- 4 = Alternative cable outlet and connector are available
- 5 = Center of rotation
- 6 = Adjustable

LE = Line element (ISO 1101: 2008)
SP = Signal periods
MR = Measuring range
MR* = Required range for electronic fine adjustment

SP/360°	23000			30000			50000			63000		
MR	10°	23°	36°	8°	16°	31°	5°	11°	21°	4°	8°	15°
MR*	6.6°			5.2°			3.2°			2.4°		
A	20.98			30.2			46.95			67.95		
B	31.48			40.7			57.45			78.45		
C	5	8.4	13	5	8.4	13	5	8.4	13	5	8.4	13
D	10	13.4	22.9	10	13.4	22.9	10	13.4	22.9	10	13.4	22.9

Specifications

Scanning head	AK ERP 1070							
Interface								
Reference mark signal	Square-wave pulse							
Integrated interpolation*	1-fold ¹⁾	5-fold	10-fold	25-fold	50-fold	100-fold	500-fold	1000-fold
Scanning frequency ²⁾	≤ 450 kHz	≤ 312.5 kHz		≤ 250 kHz	≤ 125 kHz	≤ 62.5 kHz	≤ 12.5 kHz	≤ 6.25 kHz
Edge separation <i>a</i>	≥ 0.125 μs	≥ 0.135 μs	≥ 0.07 μs	≥ 0.03 μs				
Electrical connection*	15-pin D-sub connector (male) with 0.5 m/1 m/1.5 m cable, interface electronics in the connector; cable outlet: left or right and straight or angled							
Cable length	With HEIDENHAIN cable: ≤ 20 m; during signal adjustment with the PWM 21: ≤ 3 m							
Supply voltage	DC 5 V ±0.5 V							
Current consumption	≤ 300 mA (without load)							

Scanning head	AK ERP 1080							
Interface								
Reference mark signal	Square-wave pulse							
Cutoff frequency -3 dB	≥ 1 MHz							
Electrical connection*	15-pin D-sub connector (male) with 0.5 m/1 m/1.5 m/3 m cable; 12-pin SHR-12V-S connector (female) with 0.5 m/1 m/1.5 m/3 m cable; cable outlet: left or right and straight or angled							
Cable length	With HEIDENHAIN cable: ≤ 20 m; during signal adjustment with the PWM 21: ≤ 3 m							
Supply voltage	DC 5 V ±0.5 V							
Current consumption	≤ 150 mA (without load)							

* Please select when ordering

¹⁾ Suitable for applications that measure the time between the individual clock edges of the TTL output signals; non-clocked output signals permit low edge jitter

²⁾ Maximum scanning frequency during referencing: 70 kHz

Scanning head	AK ERP 1010
Interface	EnDat 2.2 ¹⁾
Ordering designation	EnDat22
Clock frequency	≤ 16 MHz
Calculation time t_{cal}	≤ 5 μs
Electrical connection*	15-pin D-sub connector (male) with 0.5 m/1 m/1.5 m/3 m cable; interface electronics inside the connector; cable outlet: left or right and straight or angled
Cable length	With HEIDENHAIN cable: ≤ 100 m; during signal adjustment with the PWM 21: ≤ 3 m
Supply voltage	DC 3.6 V to 14 V
Power consumption (max.)	At 3.6 V: 1220 mW; at 14 V: 1430 mW
Current consumption (typical)	At 5 V: 175 mA (without load)

¹⁾ Absolute position value after crossing of the reference mark in "Position value 2"

Scanning head	General (AK ERP 1070 / AK ERP 1080 / AK ERP 1010)
Vibration 55 Hz to 2000 Hz Shock 6 ms	≤ 500 m/s ² (EN 60068-2-6) ≤ 1000 m/s ² (EN 60068-2-27)
Operating temperature	-10 °C to 70 °C
Protection	IP50
Mass Scanning head Connector Cable	≈ 5 g (without cable) ≈ 75 g ≈ 22 g/m

Circular scale	TKN ERP 1000 (full circle)			
Measuring standard	OPTODUR graduation on glass			
Signal periods*	23000	30000	50000	63000
Accuracy of graduation ¹⁾	±4"	±3"	±1.8"	±1.5" or ±0.9"
Position error per signal period ²⁾	±0.06"	±0.04"	±0.025"	±0.02"
RMS position noise (1 MHz)	0.006"	0.004"	0.003"	0.002"
Positions/rev. ³⁾	376832000	491520000	819200000	1032192000
Measuring step ³⁾	0.0034"	0.0026"	0.0016"	0.0013"
Reference marks	One			
Inside diameter of hub	13 mm	32 mm	62 mm	104 mm
Outside diameter of circular scale	57 mm	75 mm	109 mm	151 mm
Mech. permissible speed	≤ 2600 rpm	≤ 2000 rpm	≤ 1200 rpm	≤ 950 rpm
Elec. permiss. shaft speed ³⁾⁴⁾	≤ 2600 rpm	≤ 2000 rpm	≤ 1200 rpm	≤ 950 rpm
Moment of inertia	$1.6 \cdot 10^{-5} \text{ kgm}^2$	$5.7 \cdot 10^{-5} \text{ kgm}^2$	$3.1 \cdot 10^{-4} \text{ kgm}^2$	$1.1 \cdot 10^{-3} \text{ kgm}^2$
Protection EN 60529	Complete, mounted encoder: IP00			
Mass	≈ 57 g	≈ 92 g	≈ 185 g	≈ 289 g

* Please select when ordering

1) When centered with two scanning heads

2) The position error within one signal period and the accuracy of the graduation together determine the encoder-specific error; for additional error resulting from the mounting and bearing of the measured shaft, see *Measuring accuracy* in the brochure *Modular Angle Encoders with Optical Scanning*

3) With serial interface

4) With TTL serial interface and depending on the selected interpolation

Circular scale	TKN ERP 1002 (segment)			
Measuring standard	OPTODUR graduation on glass			
Signal periods*	23 000	30 000	50 000	63 000
Position error per signal period	±0.06"	±0.04"	±0.025"	±0.02"
RMS position noise (1 MHz)	0.006"	0.004"	0.003"	0.002"
Positions/rev. ¹⁾ over 360°	376 832 000	491 520 000	819 200 000	1 032 192 000
Measuring step ¹⁾	0.0034"	0.0026"	0.0016"	0.0013"
Reference marks	One			
Measuring range	10°/23°/36°	8°/16°/31°	5°/11°/21°	4°/8°/15°
Elec. permiss. shaft speed ¹⁾²⁾	≤ 2600 rpm	≤ 2000 rpm	≤ 1200 rpm	≤ 950 rpm
Protection EN 60529	Complete, mounted encoder: IP00			
Mass	≈ 0.6 g/1 g/1.7 g			

* Please select when ordering

¹⁾ With serial interface

²⁾ With TTL serial interface and depending on the selected interpolation

Signal-quality indicator

The ERP 1010 and ERP 1070 modular angle encoders feature an integrated signal-quality indicator with a multicolor LED, permitting fast and easy signal-quality checks during operation.

This feature provides a number of benefits:

- Scanning-signal quality visualization via a multicolor LED
- Continuous monitoring of incremental signals over the entire angular measurement range
- Indication of the reference-mark signal behavior
- Quick signal-quality checks in the field without additional aids

The built-in status indicator permits a reliable assessment of the incremental signals and inspection of the reference mark signal. The quality of the **incremental signals** is indicated by different colors. A blue LED indicates traversal of the reference mark.



ERP 1010 and ERP 1070:
Signal-quality indicator in the interface electronics

LED indicator for incremental signals

LED color	Quality of the scanning signals
●	Optimal
●	Acceptable
●	Unsatisfactory

In the encoders with a serial interface (ERP 1010), an error bit is set when a red LED is displayed. Error bits can be displayed and cleared with the ATS mounting wizard.

LED indicator for the reference mark signal

When the reference mark is traversed, the LED briefly switches to blue. In the ERP 1070 encoders, the LED can also be used for checking the reference mark signal:

- Out of tolerance
- In tolerance

LED indicator for control margin

In the encoders with a TTL interface (ERP 1070), a flashing LED (briefly goes dark every 2.5 s) indicates when the control margin of the scanning ASIC (HSP) is nearly exhausted. Clean the measuring standard and the scanning window of the scanning head in compliance with the relevant information in the mounting instructions. The encoder may also need to be checked for correct mounting.

Cable outlets

Right-side cable outlet



Right-side cable outlet, angled (0°)

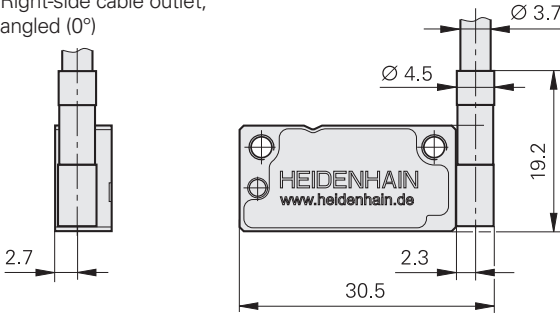

Left-side cable outlet

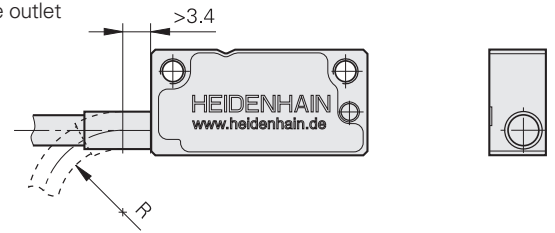

Left-side cable outlet, angled (0°)

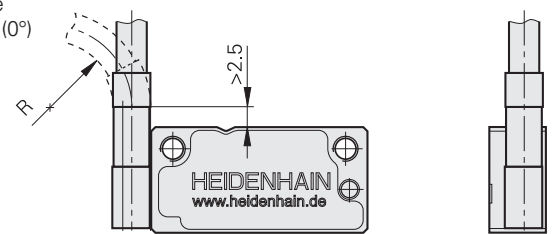

Cable bend radius **R**

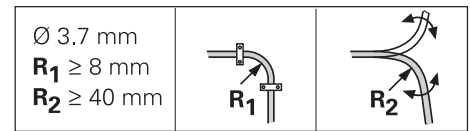

Connectors

D-SUB $\sim 1 V_{PP}$ TTL, EnDat

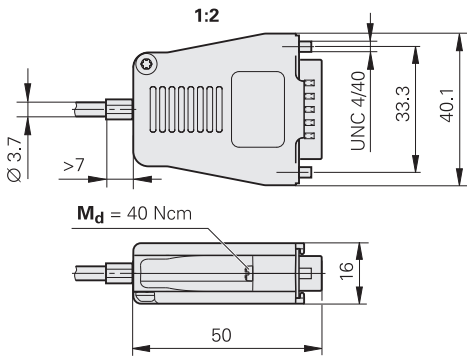

SHR-12V-S $\sim 1 V_{PP}$

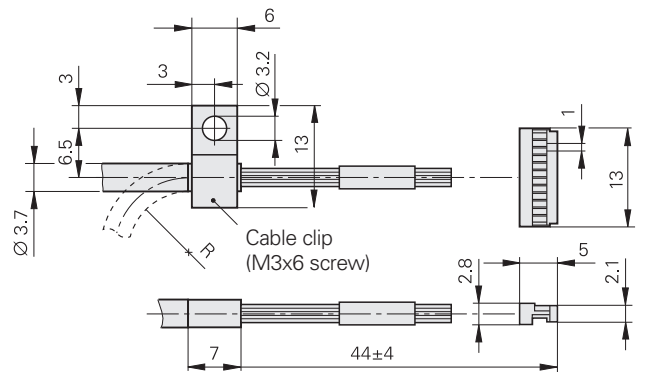

Pre-adjustment



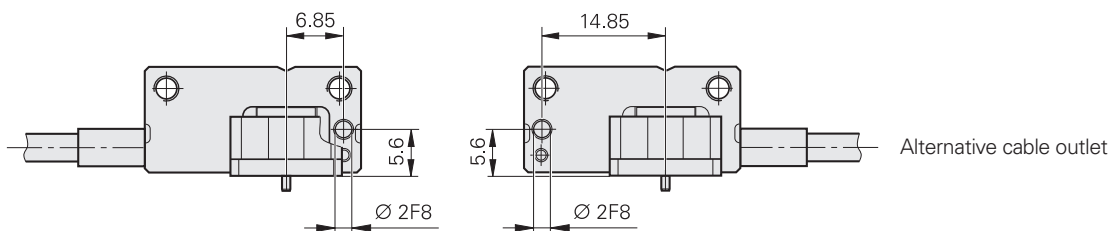

Optional pre-adjustment of the scanning head by means of a pin ($\varnothing 2 \text{ mm}$).



Electrical connection

Pin layout

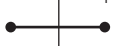
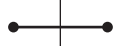
Pin layout

15-pin D-sub connector (male)					12-pin SHR-12V-S connector (female)										
	Power supply				Incremental signals						Serial data transmission/ other signals				
	4	12	2	10	1	9	3	11	14	7	13	15	5	6	8
	1	-	2	-	3	4	6	5	8	7	9	11	12	10	/
EnDat	U _P	Sensor U _P	0V	Sensor 0V	/	/	/	/	/	/	DATA	CLOCK	DATA	Vacant	CLOCK
TTL					U _{a1}	$\overline{U_{a1}}$	U _{a2}	$\overline{U_{a2}}$	U _{a0}	$\overline{U_{a0}}$	$\overline{U_{aS}}$	Vacant	Vacant ¹⁾	Vacant ¹⁾	Vacant ¹⁾
					A+	A-	B+	B-	R+	R-	Vacant ¹⁾	Vacant ¹⁾	Vacant	Vacant	Vacant
	Brown/ Green	/	White/ Green	/	Brown	Green	Gray	Pink	Red	Black	Violet	Yellow	/	/	/

Shield lies on housing; **U_P** = Power supply voltage





Sensor: The sense line is connected in the connector with the corresponding power line.

Vacant wires and pins must not be used.

¹⁾ Required for signal adjustment with the PWM 21



Cables

1 V_{PP} TTL adapter cables and connecting cables

PUR 6 x (2 x 0.19 mm ²); A _P = 2 x 0.19 mm ²			
PUR 4 x (2 x 0.14 mm ²) + (4 x 0.5 mm ²); A _P = 2 x 0.5 mm ²		Ø 8 mm	Ø 6 mm ¹⁾
Adapter cable with 15-pin D-sub connector (female) and 12-pin M23 connector (male)		331693-xx	355215-xx
Adapter cable with 15-pin D-sub connector (female) and 15-pin D-sub connector (male)		335074-xx	355186-xx
Connecting cable with 15-pin D-sub connector (female) and stripped cable end		332433-xx	355209-xx
Connecting cable with 15-pin D-sub connector (female) and pin layout for the IK 220		335077-xx	349687-xx
Signal cable with stripped cable ends (for 15 pins)		816317-xx	816323-xx

¹⁾ Cable length for Ø 6 mm: max. 9 m
A_P: Cross section of power supply lines

EnDat adapter cable and connecting cable

2 x (2 x 0.09 mm ²) + 2 x (2 x 0.16 mm ²); A _P = 2 x 0.16 mm ²		Ø 6 mm
Adapter cable with 15-pin D-sub connector (female) and 8-pin M12 coupling (male)		1120686-xx
Connecting cable with 15-pin D-sub connector (female) without locking screws, and 15-pin D-sub connector (male)		1080091-xx

A_P: Cross section of supply lines

Accessory

Adapter connector from SHR-12V-S to D-sub for signal adjustment with the PWM 21

1234385-01

HEIDENHAIN

DR. JOHANNES HEIDENHAIN GmbH

Dr.-Johannes-Heidenhain-Straße 5

83301 Traunreut, Germany

 +49 8669 31-0

 +49 8669 32-5061

E-mail: info@heidenhain.de

www.heidenhain.de

This Product Information document supersedes all previous editions, which thereby become invalid. The basis for ordering from HEIDENHAIN is always the Product Information document edition valid when the order is placed.



Further information:

- Brochure: *Modular Angle Encoders with Optical Scanning* 1222041-xx
- Brochure: *Interfaces of HEIDENHAIN Encoders* 1078628-xx